

| 项目 | 名称 | 材料料号 | 组成用量 |
|----|-----|----------------------|------|
| 1 | 端子1 | 411906014A-29-01-1S3 | 10 |
| 2 | 端子2 | 411906014A-29-01-2S3 | 1 |
| 3 | 端子3 | 411906014A-29-01-3S3 | 1 |
| 4 | 塑胶 | WYX-411906014A-29-01 | 1 |

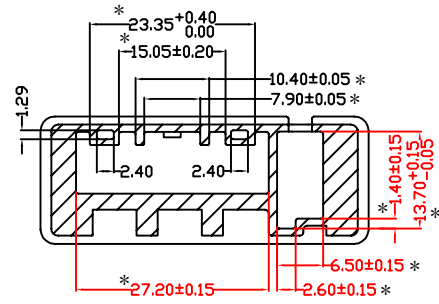
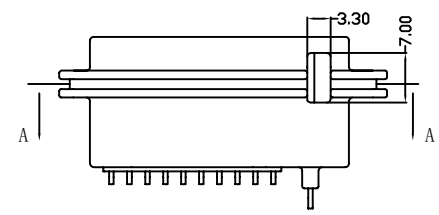
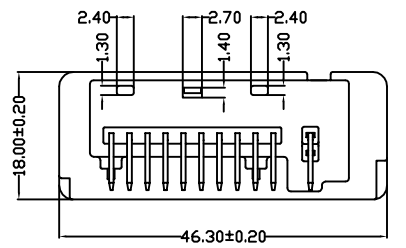
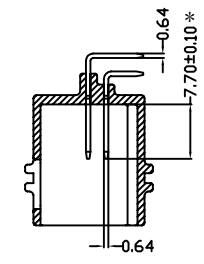
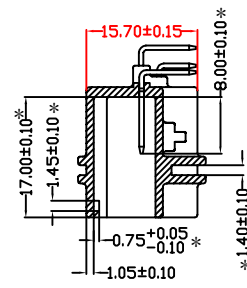
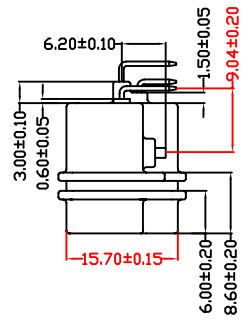
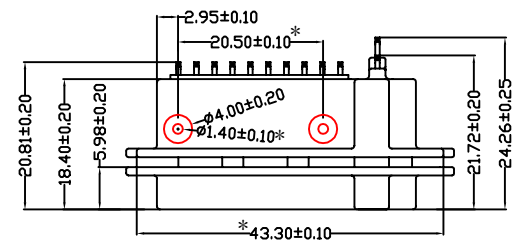
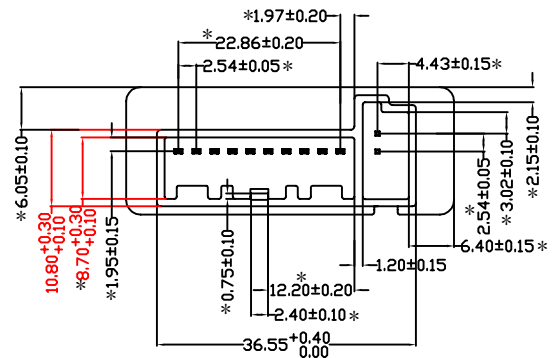

技术要求

- 1、材质:高温尼龙,黑色,禁止使用二次料,阻燃性能要求按照GB 8410-执行燃烧速率≤80mm/min;
- 2、气味性试验按照Q/BYDQ-1901.404-2018中4.5.1所示,其界定值为≤3.0级;
- 3、挥发性有机物(VOC)依照《Q/BYDQ-A1901.771乘员舱内零部件挥发性有机物和醛酮类物质检测方法》执行;
- 4、禁限用物质需要满足《GB/T 30512-2014汽车禁用物质要求》;
- 5、成形后制件应光整不得有扭曲现象;
- 6、外表光滑,且不得有划伤,刻痕等缺陷,内部不得出现毛刺;
- 7、未标注尺寸参照数模;
- 8、与控制器底座、盖板、电路板等匹配良好,无晃动;
- 9、未注尺寸公差按GB/T1804-m级执行;
- 10、未注圆角: R 0.1-2.0;
- 11、插针的材质为磷铜C5191,表面处理为镀锡,拉拔力≥2Kg.

| | | | | | | | | | | |
|-----|------|--------|--------------------------|-------------|-------|---------|---------------------------------------------------------|----------------|----------|-----------------------------------------------|
| | | | | OPERATION | SCALE | Fit | 东莞市瑞翔精密连接器有限公司 Dongguan Ruixiang Electronic Co.,Ltd. | | | |
| | | | | X.X ±0.25 | UNIT | MM | | | | |
| | | | | X.XX ±0.20 | SIZE | A4 | DESIGN | 周芳杰 2023.10.12 | PART NO. | YX-411906014A-29-01 |
| | | | | X.XXX ±0.10 | SHEET | 1/1 | CHECK | | TITLE: | 2.54间距扁针 10+2P 90度 带柱 磷铜 高温尼龙料 镀高温亮锡 K2008 |
| REV | DATE | SYMBOL | MODIFICATION DESCRIPTION | Angle ±3° | PROJ. | APPROVE | Customer No. | | | |
| | | | | DIM TOL | | | | | | |